

ABOUT



SINCE 1972

SATORI has been a leading supplier to the bicycle industry over 50 years, with a focus on providing innovative handlebars, stems and seat posts to bicycle assemblers and consumers globally.

As could be expected from one of the world's largest component manufacturers, we are equipped with world-class research, design and production facilities, as well as the experience to back it up. Above all though, a passion for riding is the driving force behind our company direction and it is this deep rooted 'bicycle-minded' philosophy that fuels the development of exciting new ideas at SATORI Taiwan.

STEMS

- 6 ICR STEMS
- 18 ADJUSTABLE STEMS
- 19 RIGID STEMS
- 20 TOOL-FREE STEMS
- 22 SHOCK ABSORBING STEMS
- 24 RISER STEMS
- 25 TURNABLE STEM

HANDLEBARS

- 26 MTB HANDLEBARS
- 30 TREKKING HANDLEBARS
- 34 LIGHT INTEGRATED COCKPIT
- 36 ROAD / GRAVEL HANDLEBARS
- 41 INTEGRATED HANDLEBARS
- 42 KIDS SECTION

SEATPOSTS

- 43 SUSPENSION SEATPOSTS
- 46 SPECIAL SEATPOST
- 47 TELESCOPING SEATPOSTS
- 48 DROPPER POSTS
- 50 SEATPOSTS

CARBON

- 53 CARBON SERIES

ACCESSORIES

- 54 ACCESSORIES
- 56 SPECIFICATION

ICON

STEMS



ADJUSTABLE
Easy adjustment.



TOOL FREE
Easy adjustment with your hands.



EASY TURN
One Side Turn.



EASY TURN
One Side Turn.



DUO
Two adjustments in one.



S³
SATORI square system



ICR
Internal Cable Routing

HANDLEBARS



BUTTED TECHNOLOGY
Light weight and high strength.



WING SHAPE
Comfort hand grip.



FLARED DROP



STRONG & STIFF
Aggressive test



Ø35
35mm bar bore

SEATPOSTS



ANTI-SIDEPLAY
No Side-play adjustment for suspension and dropper system



COIL SPRING



STEMS

HANDLEBARS



PATENTED



S³ - SATORI SQUARE SYSTEM

SEATPOSTS



CARBON SERIES

PARTNERS



ACCESSORIES



AIX-525



AZX-581



AZX-585



AZX-727



HS-HL-01



NO.69 / 56 / SRS / Middle / HL-Delta



TK1566PS1



TK1566PS2



STEMS

HANDLEBARS

SEATPOSTS

CARBON SERIES

LIGHT PARTNERS



ACCESSORIES

STEMS

HANDLEBARS

SEATPOSTS

CARBON SERIES

ACCESSORIES



BELUGA



BOSCH Kiox 400C

STEMS

HANDLEBARS

SEATPOSTS

CARBON SERIES

ACCESSORIES

BELUGA



This high-performance adjustable stem is designed specifically for OEMs seeking clean integration and flexibility in e-bike assembly. It offers full compatibility with the BOSCH 400C display, which mounts directly into the stem without additional brackets, reducing cockpit complexity and part count.

Approved for ASTM Cat. 2 ETK 180Kg

MATERIAL	FORGED AL
EXTENSION	90 mm
BAR BORE	Ø31.8 mm
STEERER	Ø28.6 mm
ANGLE	0° ~ +50°
STEERER DEPTH	39 mm
WEIGHT	656 g

OPTIONAL

For more accessories please refer to P.54



S³ ADAPTOR



S³ LIGHT MOUNT



BOXTER



STEMS

HANDLEBARS

SEATPOSTS

CARBON SERIES

ACCESSORIES





Compatible with INTUVIA 200

Compatible with KIOX 300 / 500 display



Wireless Charging Head



BOXTER



BOXTER-Charger



The new BOXTER stem is designed for seamless semiintegration with the BOSCH Intuvia 200 display, while also supporting Kiox 300 / 500 for the same semiintegrated setup.

Approved for ASTM Cat. 2 ETK 180Kg

MATERIAL	FORGED AL
EXTENSION	80 mm
BAR BORE	Ø31.8 mm
STEERER	Ø28.6 mm
ANGLE	10° ~ +90°
STEERER DEPTH	39 mm
WEIGHT	503 g

Exclusive adjustable stem with Quad Lock® Wireless Charging Head (**SOLD SEPARATELY**)

Approved for ASTM Cat. 2 ETK 180Kg

MATERIAL	FORGED AL
EXTENSION	80 mm
BAR BORE	Ø31.8 mm
STEERER	Ø28.6 mm
ANGLE	10° ~ +90°
STEERER DEPTH	39 mm
WEIGHT	557 g



OPTIONAL

For more accessories please refer to P.54



S³ LIGHT MOUNT



S³ ADAPTOR

STEMS

HANDLEBARS

SEATPOSTS

CARBON SERIES

ACCESSORIES

S³ CAP optional

Front brake cable with ICR

Special top cap allows easy to maintain the front brake cable through by special star nut.

Rear brake / Shift / Electronic cables with ICR

RANA



STEMS

HANDLEBARS

SEATPOSTS

CARBON SERIES

ACCESSORIES

RANA

Featuring ICR internal cable routing and capability for the front brake cable housing to run through the fork steerer tube, the Rana stem provides true fully concealed cable routing look. The removable top cap allows easy access to the front brake cable housing for assembling or maintenance.

Approved for ASTM Cat. 2 ETK 180Kg

MATERIAL	FORGED AL
EXTENSION	70 / 90 / 110 mm
BAR BORE	Ø31.8 mm
STEERER	Ø28.6 mm
ANGLE	+20°
STEERER DEPTH	39 mm
WEIGHT	309.5 g



including special star nut and protection cover

OPTIONAL

For more accessories please refer to P.54



KIOX 300 adaptor



INTUVIA 100 adaptor



S³ CAP



EL-012 light mount adaptor



GoPro MOUNT for standard faceplate



STARSTREAM MINI faceplate





40 / 70 mm



50 / 80 mm



60 / 90 mm

SLINGSHOT

Designed to pair with handlebars integrating Supernova's Starstream light unit, angle adjustability and ICR system, wide-body design opens up possibilities for further accessory integration.

Approved for ASTM Cat. 2 ETK 180Kg

MATERIAL	FORGED AL
EXTENSION	70 mm
BAR BORE	Ø31.8 mm
STEERER	Ø28.6 mm
ANGLE	0° ~ +90°
STEERER DEPTH	39 mm
WEIGHT	503 g



ICR

Adjustable

S³

OPTIONAL

For more accessories please refer to P.54



Compatible with
Kiox 300 display



Compatible with
Intuvia 100 display



EL-045
Light mount for
SLINGSHOT

• The MOBY DEE not only offer angle adjustability for rider comfort, it also features SATORI's unique extension adjustment system—allowing the extension to be set 40 ~ 60mm or 70 ~ 90mm without changing components.

MOBY DEE



Approved for ASTM Cat. 2 ETK 180Kg

MATERIAL	FORGED AL
EXTENSION	40 ~ 60 / 70 ~ 90 mm
BAR BORE	Ø31.8 mm
STEERER	Ø28.6 mm
ANGLE	0° ~ +90°
STEERER DEPTH	39 mm



ICR

Adjustable

S³

OPTIONAL

For more accessories please refer to P.54

S³ ADAPTORS³ LIGHT MOUNT



OPTIONAL :



Capability for the front brake cable housing to run through the fork steerer tube

SHORTY ICR



HATCHBACK ICR



Approved for ASTM Cat. 4 EMTB 150Kg

Approved for ASTM Cat. 2 ETK 180Kg

MATERIAL	FORGED AL
EXTENSION	40 / 60 mm
BAR BORE	Ø31.8 / Ø35 mm
STEERER	Ø28.6 mm
ANGLE	10° ~ +90°
STEERER DEPTH	39 mm
WEIGHT	380.7 g (Ø31.8 x 40 mm)

MATERIAL	FORGED AL
EXTENSION	60 / 80 / 100 mm
BAR BORE	Ø31.8 mm
STEERER	Ø28.6 mm
ANGLE	0° ~ +90°
STEERER DEPTH	39 mm
WEIGHT	433.5 g (90 mm)



OPTIONAL

For more accessories please refer to P.54



688B CAP
for bar bore 35mm



S³ LIGHT MOUNT



KIOX 300 adaptor



INTUVIA 100 adaptor



671B CAP
for bar bore 31.8mm



BOSCH KIOX
KIOX 300
SHIMANO E6000

OPTIONAL :



Capability for the front brake cable housing to run through the fork steerer tube

PYTHON

Approved for ASTM Cat. 2 ETK 180Kg

MATERIAL	FORGED AL
EXTENSION	65 / 90 / 110 mm
BAR BORE	Ø31.8 mm
STEERER	Ø28.6 mm
ANGLE	0° ~ +90°
STEERER DEPTH	39 mm
WEIGHT	455.5 g (E:65)



OPTIONAL

For more accessories please refer to P.54



KIOX 300 adaptor

INTUVIA 100 adaptor

671B CAP

S³ ADAPTOR

CATAMARAN

Approved for ASTM Cat. 2 ETK 180Kg

MATERIAL	FORGED AL
EXTENSION	95 mm
BAR BORE	Ø31.8 (W/Shim) / Ø35 mm
STEERER	Ø28.6 mm
ANGLE	0° ~ +90°
STEERER DEPTH	39 mm
WEIGHT	604.5 g (Ø35 E:95)



OPTIONAL

Light mount for CATAMARAN



EL-018



Special cutout for cable routing on both side



OPTIONAL : GoPro MOUNT
For standard faceplate



VIPER AERO



MATERIAL	3D FORGED AL
EXTENSION	60 / 70 / 80 / 90 / 100 / 110 / 120 mm
BAR BORE	Ø31.8 mm
STEERER	Ø28.6 mm
ANGLE	-7°
STACK	33 mm
WEIGHT	235g (E:100)



NEW VIPER

MATERIAL	3D FORGED AL
EXTENSION	60 / 70 / 80 / 90 / 100 / 110 / 120 mm
BAR BORE	Ø31.8 mm
STEERER	Ø28.6 mm
ANGLE	-7°
STACK	33 mm
WEIGHT	213.5 g (E:100)



OPTIONAL

For more accessories please refer to P.54

compatible with Starstream mini head light



EL-012 Light
mount adaptor

OPTIONAL

For more accessories please refer to P.54



EL-012 Light
mount adaptor



S³ CAP



STARSTREAM MINI
faceplate

STEMS

HANDLEBARS

SEATPOSTS

CARBON SERIES

ACCESSORIES



OPTIONAL : GoPro MOUNT
For standard faceplate



VIPER 0

Approved for ASTM Cat. 3 EXC

MATERIAL	3D FORGED AL
EXTENSION	45 / 60 / 80 mm
BAR BORE	Ø31.8 mm
STEERER	Ø28.6 mm
ANGLE	0°
STACK	42 mm
WEIGHT	235.5 g (E:80)



OPTIONAL

For more accessories please refer to P.54



S³ CAP



EL-012 Light mount adaptor



STARSTREAM MINI faceplate



LIVE

Approved for ASTM Cat. 4 EMTB 150Kg

MATERIAL	FORGED AL
EXTENSION	35 / 45 mm
BAR BORE	Ø35 mm
STEERER	Ø28.6 mm
ANGLE	0°
STACK	40 mm
WEIGHT	129 g (E:35)



OPTIONAL

For more accessories please refer to P.54



EL-012 Light mount adaptor



URSA

Approved for ASTM Cat. 4 EMTB 150Kg

MATERIAL	FORGED AL
EXTENSION	35 / 50 mm
BAR BORE	Ø31.8 / Ø35 mm
STEERER	Ø28.6 mm
ANGLE	0°
STACK	41 mm
WEIGHT	224 g (Ø31.8 x E:50)



OPTIONAL

For more accessories please refer to P.54



EL-012 Light mount adaptor



SIDEWINDER

Approved for Cat.2 ETK 180Kg

MATERIAL	3D FORGED AL
EXTENSION	80 / 90 / 110 mm
BAR BORE	Ø31.8 mm
STEERER	Ø28.6 mm
ANGLE	+7°
STACK	40 mm
WEIGHT	246 g (E:100)

ICR
ICR

S³
S³



FASTBACK 20

Approved for ASTM Cat. 5 ADV. PLUS

MATERIAL	3D FORGED AL
EXTENSION	50 / 70 / 90 / 110 mm
BAR BORE	Ø31.8 mm
STEERER	Ø28.6 mm
ANGLE	+20°
STEERER DEPTH	40 mm
WEIGHT	246.5 g (E:70)

ICR
ICR

S³
S³



FASTBACK 35

Approved for ASTM Cat. 5 ADV. PLUS

MATERIAL	3D FORGED AL
EXTENSION	70 / 90 / 110 mm
BAR BORE	Ø31.8 mm
STEERER	Ø28.6 mm
ANGLE	+35°
STEERER DEPTH	40 mm
WEIGHT	259.5 g

ICR
ICR

S³
S³

OPTIONAL

For more accessories please refer to P.54



KIOX 300 adaptor



INTUVIA 100 adaptor



671B CAP



EL-019
Transition spacer for use
with ACROS AZX-581



S³ ADAPTOR



OPTIONAL : EL-025 (S³ adaptor)

STEMS

HANDLEBARS

SEATPOSTS

CARBON SERIES

ACCESSORIES

HATCHBACK

Approved for ASTM Cat. 2 ETK 180Kg

MATERIAL	FORGED AL
EXTENSION	70 / 90 / 110 mm
BAR BORE	Ø31.8 mm
STEERER	Ø28.6 mm
ANGLE	0° ~ +90°
STEERER DEPTH	39 mm
WEIGHT	433.5 g (90 mm)



OPTIONAL
For more accessories please refer to P.54

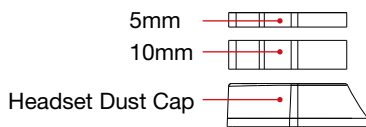

671B CAP



EL-010 & SPR-010 Headset dust cap and Spacer

UP3

MATERIAL	3D FORGED AL
EXTENSION	65 / 90 / 110 mm
BAR BORE	Ø31.8 mm
STEERER	Ø28.6 mm
ANGLE	0° ~ +90°
STEERER DEPTH	39 mm
WEIGHT	400 g (E:110)



OPTIONAL
For more accessories please refer to P.54



KIOX 300 adaptor



INTUVIA 100 adaptor



379 CAP



380F CAP



TURN-UP

MATERIAL	3D FORGED AL
EXTENSION	100 / 120 mm
BAR BORE	Ø25.4 / Ø31.8 mm
STEERER	Ø28.6 mm
ANGLE	0° ~ +90° / -80° ~ +80°
STACK	42 mm
WEIGHT	268 g (Ø31.8 x E:100)



Adjustable



Duo



COBRA

MATERIAL	FORGED AL
EXTENSION	100 mm
BAR BORE	Ø25.4 / Ø31.8 mm
STEERER	Ø28.6 mm
ANGLE	-40° ~ +80° / +50° ~ -50°
STACK	41 mm
WEIGHT	306 g (Ø31.8)



Adjustable



Duo

RIGID STEMS



SCORPION

MATERIAL	3D FORGED AL
EXTENSION	45 / 60 mm
BAR BORE	Ø31.8 mm
STEERER	Ø28.6 mm
ANGLE	-7°
STACK	40 mm
WEIGHT	144.5 g (E:80)



MAMBA

MATERIAL	3D FORGED AL
EXTENSION	80 / 90 / 100 / 110 / 120 mm
BAR BORE	Ø31.8 mm
STEERER	Ø28.6 mm
ANGLE	-7°
STACK	38 mm
WEIGHT	136 g (E:100)



EZ-X ICR

- Easy upper lever adjustment with SATORI safety button.
- Simple but powerful QR mechanism with pre-adjust screw for handlebar tolerance control.
- One-piece cold forged parts for lighter weight.
- Serrated and precisely machined handlebar clamp for powerful clamping.
- Inline pivot adjustment center for the most upright comfort position.
- Compatible with ICR (Internal Cable Routing)

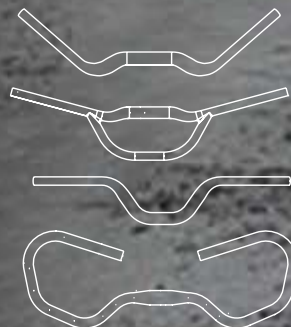
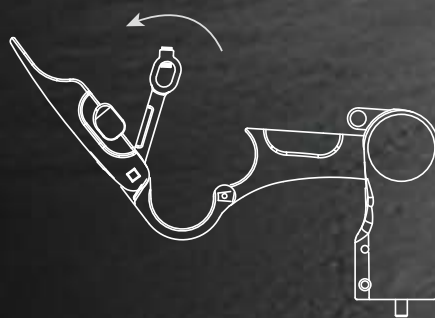



STEMS

HANDLEBARS

SEATPOSTS

CARBON SERIES

ACCESSORIES

EZ-X ICR



MATERIAL	FORGED AL
EXTENSION	90 mm
BAR BORE	Ø31.8 mm
STEERER	Ø28.6 mm
ANGLE	0° ~ +80°
STEERER DEPTH	40 mm
WEIGHT	509 g (E:110)



EZ-X

Approve for EN17860 Cargo bike standard

MATERIAL	FORGED AL
EXTENSION	90 mm
BAR BORE	Ø31.8 mm
STEERER	Ø28.6 mm
ANGLE	0° ~ +80°
STEERER DEPTH	40 mm
WEIGHT	553.5 g (E:110)



EZ3

MATERIAL	FORGED AL
EXTENSION	110 mm
BAR BORE	Ø25.4 / Ø31.8 mm
STEERER	Ø25.4 mm
ANGLE	0° ~ +80°
LENGTH	180 / 230 mm
WEIGHT	541 g (Ø25.4 x L:180)



STEMS

HANDLEBARS

SEATPOSTS

CARBON SERIES

ACCESSORIES



MODERATOR



MODERATOR



Deleting road vibration while maintaining stability and control all the way, come gravel or rough paths, the Moderator takes the buzz off your ride.

Dampening can be fine-tuned with different elastomers, done simply with a 4mm hex key.

Approved for ASTM Cat. 1 ROAD 140Kg

MATERIAL	3D FORGED AL
EXTENSION	80 / 95 / 110 mm
BAR BORE	Ø31.8 mm
STEERER	Ø28.6 mm
ANGLE	0°
STACK	50 mm
WEIGHT	350 g (E:110)



ELASTOMERS WITH DIFFERENT HARDNESS AVAILABLE AS OPTION.

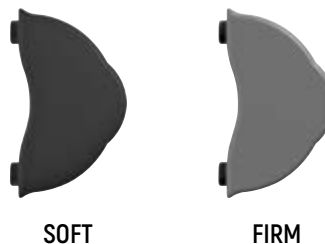

OPTIONAL

For more accessories please refer to P.54



S³ ADAPTOR



EL-012 Light mount adaptor



GoPro MOUNT



STARSTREAM MINI faceplate



EASY-UP ET

Tool-free easy adjustment of both handlebar height and its side folding.

Pull up the stanchion at top position. Turn it to side and push down the bottom

Easy assembly with the fork tube w/o additional machining of the fork tube.

Adjustment stanchion compatible with fork tube ID 24.4mm to 25.4mm.

Integrated with tightening ring for the fork tube and head parts.



EASY-UP ET

MATERIAL	AL6061
BASE DIAMETER	Ø28.6 mm
HEIGHT	110 ~ 180 mm / 110 ~ 210 mm
STEM TRAVEL	70 / 100 mm
WEIGHT	395.5 g (100 mm)



Tool Free



Turn

HEADS-UP 4

MATERIAL	AL6061
BASE DIAMETER	Ø28.6 mm
HEIGHT	117 mm
STEM ADJUSTER	10mm thick (1 spacer) 8mm thick (1 spacer) 5mm thick (2 spacer)
WEIGHT	240.5 g



SAFETY LOCK



Fold. Adjust. Lock. Save Space.

The ET-5 is a multifunctional stem designed for compact storage and modern urban mobility. Its unique folding mechanism allows the handlebar to rotate left or right, saving space when parking in tight areas or mounting bikes on camper vans or transport racks.

ET5



MAT BK

MATERIAL	FORGED AL
EXTENSION	90 mm
BAR BORE	Ø31.8 mm
STEERER	Ø28.6 mm
ANGLE	10° ~ 60°
STACK	50 mm
WEIGHT	482 g



S³



Adjustable



Tool Free



Turn



Turn

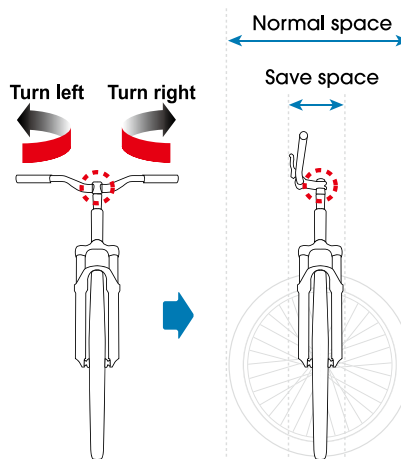

OPTIONAL

For more accessories please refer to P.54



671B CAP



KIOX 300 adaptor



INTUVIA 100 adaptor



Ø35



S&S

STRONG & STIFF

With an innovative new tube forming and butting process, we are able to achieve a whopping 35% increase in both strength and stiffness for our MTB handlebars.

EVO 35 MAX



EVO 35 FLAT



STEMS

HANDLEBARS

SEATPOSTS

CARBON SERIES

ACCESSORIES

EVO 35 MAX

Approved for Cat.4 EMTB 150Kg

MATERIAL	AL7075
BAR BORE	Ø35 mm
WIDTH	720 / 740 / 760 / 780 / 800 mm
RISE	55 mm
UP SWEEP	5°
BACK SWEEP	8° / 15°
WEIGHT	415 g



B-Tech



Ø35



S&S

EVO 35 FLAT

Approved for Cat.4 EMTB 150Kg

MATERIAL	AL7075
CENTER DIA	Ø35 mm
WIDTH	760 / 780 / 800 mm
RISE	6 mm
BACK SWEEP	8°
WEIGHT	331.5 g (W:780)



B-Tech



Ø35



S&S



STEMS

HANDLEBARS

SEATPOSTS

CARBON SERIES

ACCESSORIES

EVO 35 SMALL

Approved for Cat.4 EMTB 150Kg

MATERIAL	AL7075
CENTER DIA	Ø35 mm
WIDTH	760 / 780 / 800 mm
RISE	15 mm
UP SWEEP	5°
BACK SWEEP	7°
WEIGHT	321 g (W:780)



EVO 35 MEDIUM

**APPROVED ASTM 4
ADVANCED PLUS XXL**

MATERIAL	AL7075
CENTER DIA	Ø35 mm
WIDTH	760 / 780 / 800 mm
RISE	25 mm
UP SWEEP	5°
BACK SWEEP	7°
WEIGHT	372.5 g (W:780)



EVO 35 LARGE

Approved for Cat.4 EMTB 150Kg

MATERIAL	AL7075
CENTER DIA	Ø35 mm
WIDTH	760 / 780 / 800 mm
RISE	35 mm
UP SWEEP	5°
BACK SWEEP	8°
WEIGHT	362.5 g (W:780)



STEMS

HANDLEBARS

SEATPOSTS

CARBON SERIES

ACCESSORIES

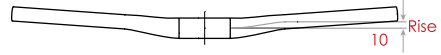

DEVIANT 1

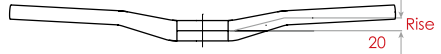

DEVIANT 2

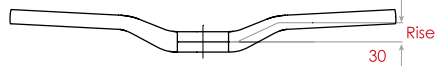

DEVIANT 3

DEVIANT 1

DEVIANT 2

DEVIANT 3

		Approved for ASTM Cat. 3 EXC	
MATERIAL	AL7050	AL7050	AL7050
CENTER DIA	Ø31.8 mm	Ø31.8 mm	Ø31.8 mm
WIDTH	680 / 700 / 720 / 740 / 760 / 780 / 800 mm	680 / 700 / 720 / 740 / 760 / 780 / 800 mm	680 / 700 / 720 / 740 / 760 / 780 / 800 mm
RISE	10 mm	20 mm	30 mm
BACK SWEEP	7°	7°	7°
WEIGHT	292 g (W:680)	372 g (W:780)	378 g (W:780)



DEVIANT 2 COVER

MATERIAL	AL6066	UP SWEEP	3°
BAR BORE	Ø31.8 mm	RISE	20 mm
WIDTH	760 / 780 / 800 mm	WEIGHT	350 g (W:780)
BACK SWEEP	7°		

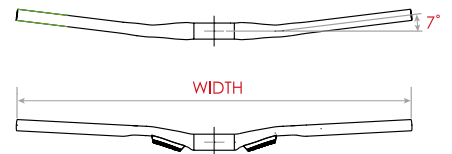



HORIZON BOW



DEVIANT BOW



FALCON

HORIZON BOW

DEVIANT BOW

FALCON

MATERIAL	AL6061
CENTER DIA	Ø31.8 mm
WIDTH	620 / 640 / 660 / 680 / 700 / 720 / 740 / 760 / 780 mm
RISE	7 mm
BACK SWEEP	9°
WEIGHT	239 g (W:700)

Approved for ASTM Cat. 2 ETK

MATERIAL	AL6061
CENTER DIA	Ø31.8 mm
WIDTH	620 / 640 / 660 / 680 / 700 / 720 / 740 / 760 / 780 mm
RISE	12 mm
BACK SWEEP	9°
WEIGHT	312 g (W:780)

MATERIAL	AL6061
CENTER DIA	Ø31.8 mm
WIDTH	620 / 640 / 660 / 680 / 700 720 / 740 / 760 mm
RISE	0 mm
BACK SWEEP	15°
WEIGHT	351 g (W:760)



B-Tech



B-Tech



B-Tech

STEMS

HANDLEBARS

SEATPOSTS

CARBON SERIES

ACCESSORIES

VERTEX



Approved for Cat.4 EMTB 150Kg

MATERIAL	AL7050
BAR BORE	Ø31.8 mm
WIDTH	720 / 740 / 760 / 780mm
BACK SWEEP	9°

UP SWEEP	5°
RISE	15 mm
WEIGHT	362 g (W:780)



B-Tech



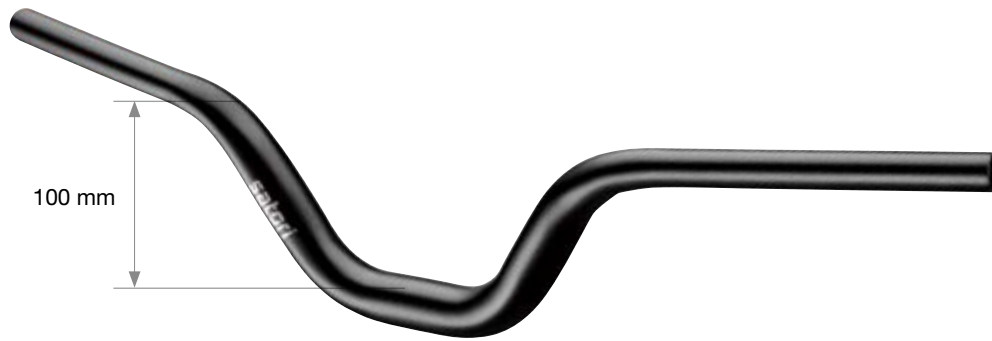

FULL CITY 100

Super high rise handlebar suitable for the E-SUV, and also passed ISO-M

MATERIAL	AL6066
BAR BORE	Ø31.8 mm
WIDTH	660 / 680 / 700 mm
RISE	100 mm
BACK SWEEP	15°
WEIGHT	366.5 g (W:680)

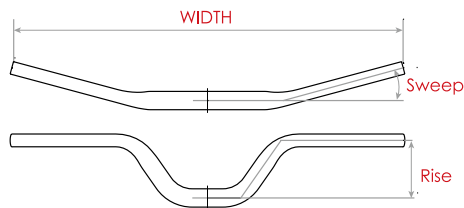

B-Tech



FULL CITY

MATERIAL	AL6066
BAR BORE	Ø31.8 mm
WIDTH	660 / 680 / 700 mm
RISE	80 mm
BACK SWEEP	15° / 30°
WEIGHT	370 g (W:700)

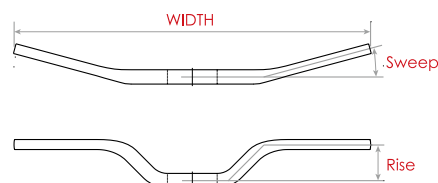

B-Tech

NOIRETTE SEAGULL

Approved for ASTM Cat.2 ETK

MATERIAL	AL6061
BAR BORE	Ø31.8 mm
WIDTH	630 / 660 / 680 mm
RISE	40 mm
BACK SWEEP	40°
WEIGHT	320 g (W:630)

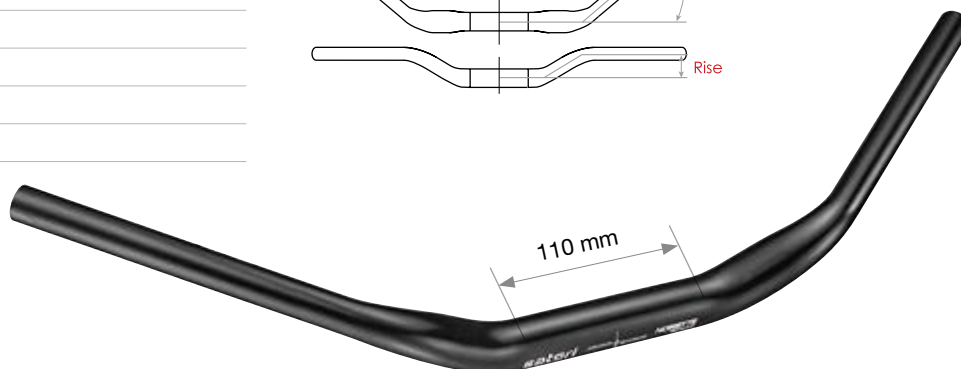
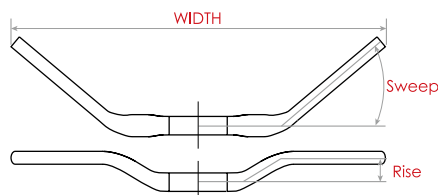

NOIRETTE PLUS WS

Approved for ASTM Cat.2 ETK

Light weight and elegant for relaxed lifestyle riding.

Flat wing shape with smooth transition from 31.8mm bar clamp for good looks & better grip.

110mm middle section for clamp-on accessories.

MATERIAL	AL6061
CENTER DIA	Ø31.8 mm
WIDTH	630 / 660 mm
RISE	34 mm
BACK SWEEP	41°
WEIGHT	331.5 g (W:660)

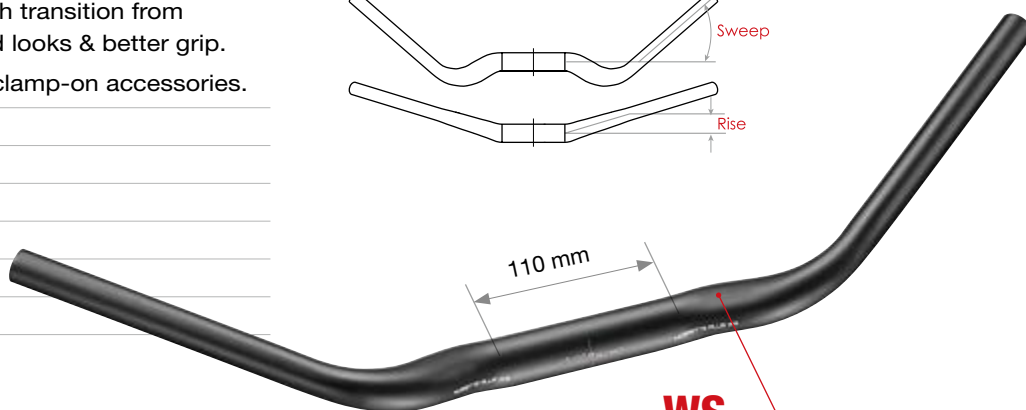
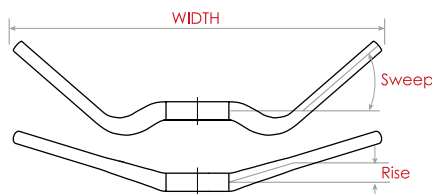

WS
FLAT, SMOOTH WING SHAPE

NOIRETTE

Approved for ASTM Cat.2 ETK

MATERIAL	AL6061
BAR BORE	Ø31.8 mm
WIDTH	600 / 630 mm
RISE	21 mm (35°) / 17 mm (15°)
BACK SWEEP	35° / 15°
WEIGHT	296.5 g (W:630 x 35°)

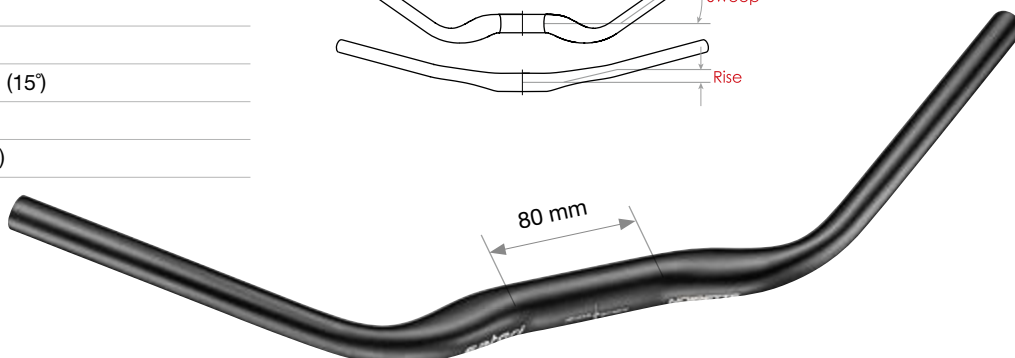
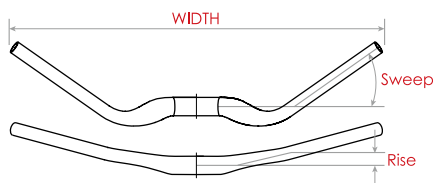

NOIR 35

Approved for ASTM Cat.2 ETK

MATERIAL	AL6061
BAR BORE	Ø35 mm
WIDTH	680 / 700 / 720 mm
RISE	15 / 35 mm
BACK SWEEP	15 mm (15° / 35°) / 35 mm (20°)
WEIGHT	303 g (W:680)

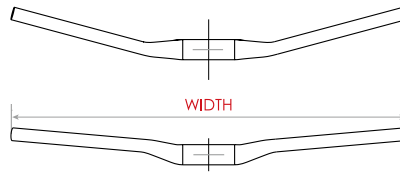

NOIR

Approved for ASTM Cat.2 ETK

MATERIAL	AL6061
CENTER DIA	Ø25.4 / Ø31.8 mm
WIDTH	600 / 630 / 660 mm
RISE	7 mm (30°) / 5 mm (15°)
BACK SWEEP	30° / 15°
WEIGHT	280.5 g (Ø31.8 x W:630, 30°)

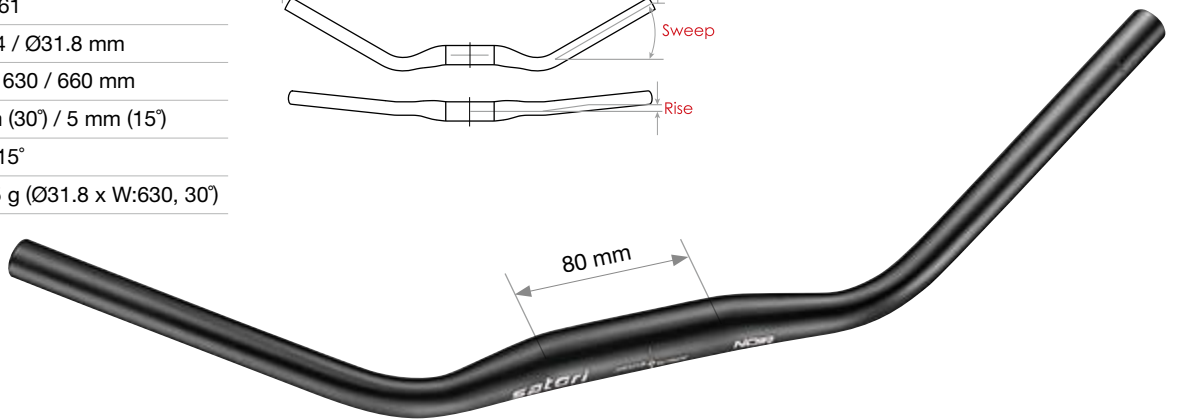
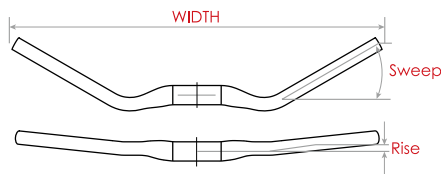

ROXETTA

**Approved for ASTM Cat. 2 ETK**

MATERIAL	AL6061
CENTER DIA	Ø31.8 mm
WIDTH	660 / 680 / 700 / 720 mm
RISE	37 mm
BACK SWEEP	10° / 20° / 30°
WEIGHT	348.5 g (W:700)

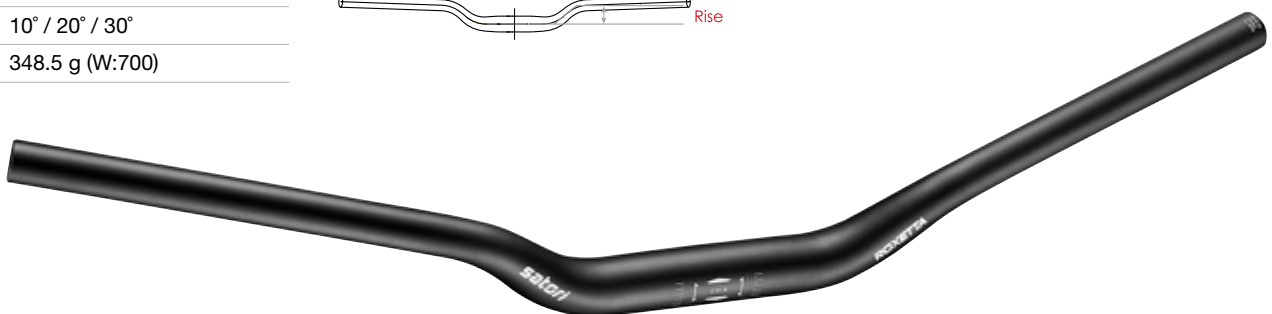
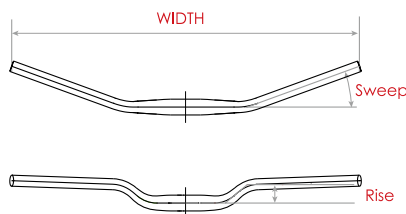

WIEN

Relaxing design for lifestyle riding.

Approved for ASTM Cat. 2 ETK

MATERIAL	AL6061
CENTER DIA	Ø31.8 mm
WIDTH	640 / 680 / 700 / 720 mm
RISE	20 mm
BACK SWEEP	35° / 15°
WEIGHT	307 g (W:640)

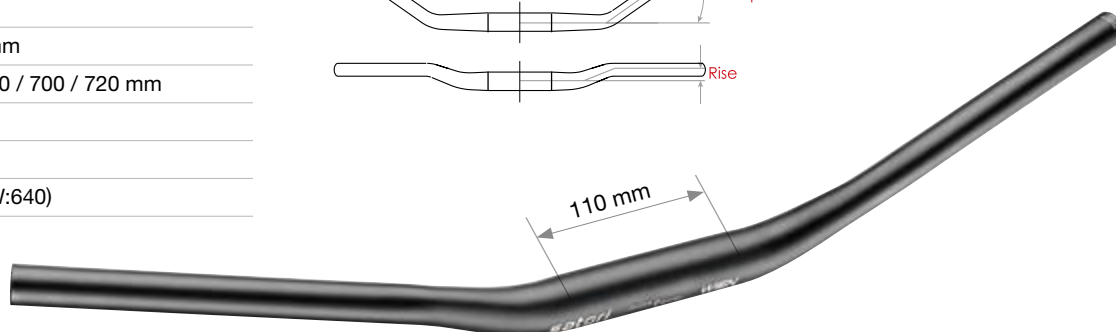
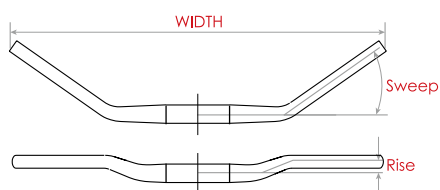

MELANGE MEDIUM

MATERIAL	AL6061
BAR BORE	Ø25.4 / Ø31.8 mm
WIDTH	560 / 570 / 595 / 615 mm
RISE	40 mm
BACK SWEEP	40°
WEIGHT	298 g (Ø31.8 x W:595)

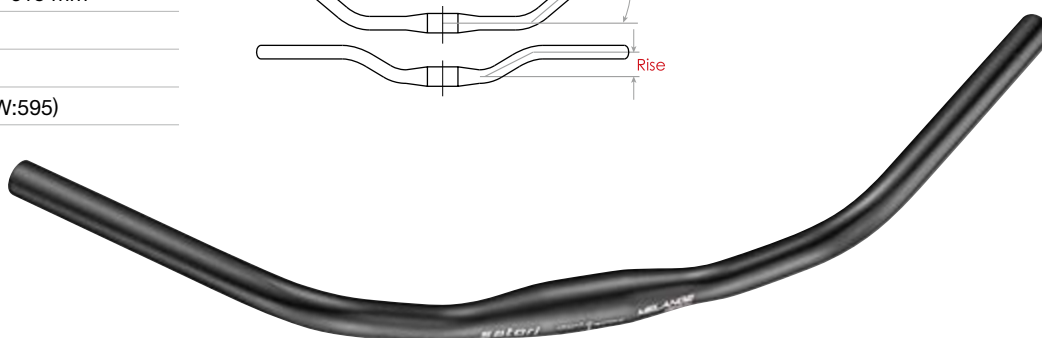
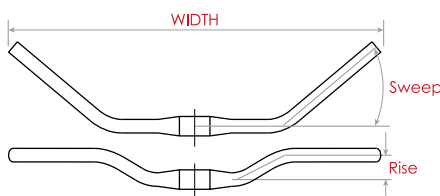

MELANGE LOW

MATERIAL	AL6061
BAR BORE	Ø25.4 / Ø31.8 mm
WIDTH	590 / 610 / 630 mm
RISE	32 mm
BACK SWEEP	46°
WEIGHT	309 g (Ø31.8 x W:590)

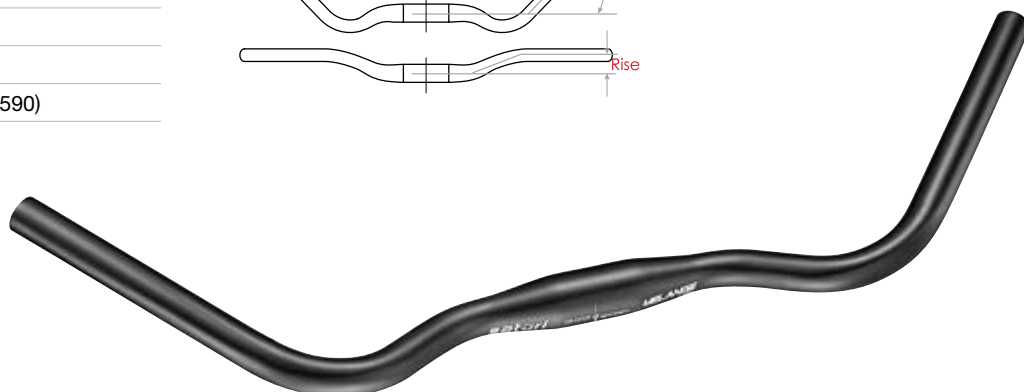
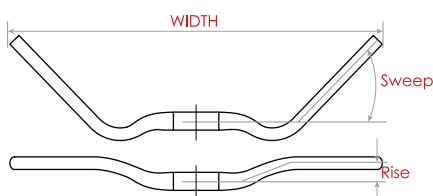



VERTEX LT VIPER 0 for Starstream Mini

SUPERNOVA 

compatible for Starstream mini



VERTEX LT



MATERIAL	AL7050
BAR BORE	Ø31.8 mm
WIDTH	720 / 740 / 760 mm
RISE	15 mm
SWEEP	9°
WEIGHT	356 g



ROXETTA LT



MATERIAL	AL6061
BAR BORE	Ø31.8 mm
WIDTH	680 / 700 / 720 mm
RISE	37 mm
BACK SWEEP	10° / 20° / 30°
WEIGHT	342 g



STEMS

HANDLEBARS

SEATPOSTS

CARBON SERIES

ACCESSORIES

Below stems compatible with STARSTREAM MINI faceplate

STEM OPTIONAL



VIPER 0



RANA



VIPER AERO



NEW VIPER

STEMS

HANDLEBARS

SEATPOSTS

CARBON SERIES

ACCESSORIES



ROAD & GRAVEL

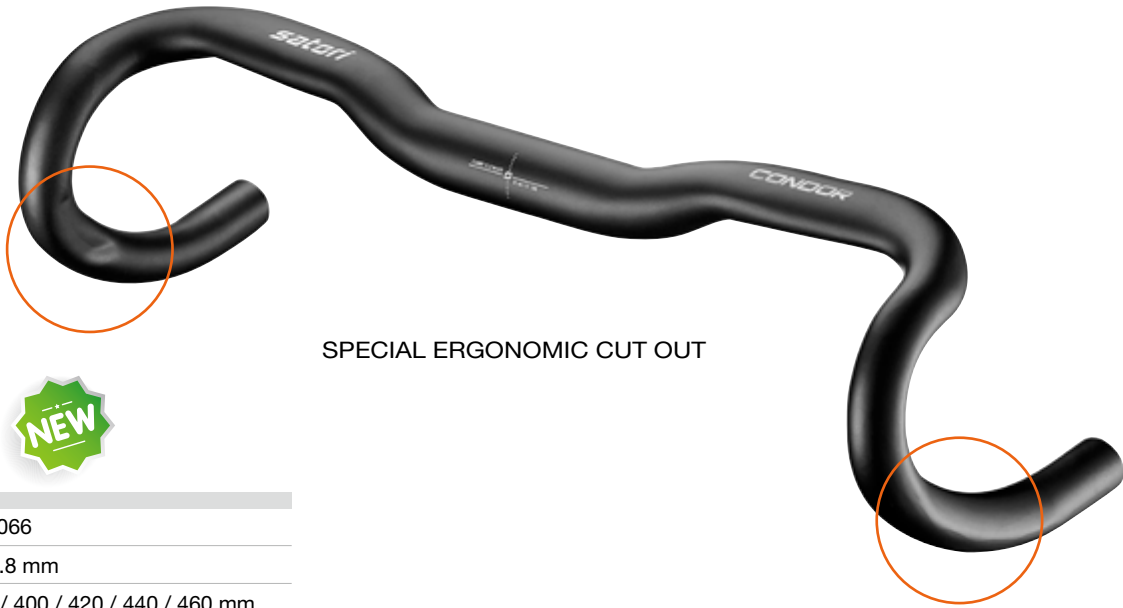

SPECIAL ERGONOMIC CUT OUT

CONDOR



MATERIAL	AL6066
BAR BORE	Ø31.8 mm
WIDTH	380 / 400 / 420 / 440 / 460 mm
RISE	10 mm
Drop	100 mm
REACH	60 mm
FLARE	8 / 16 degree

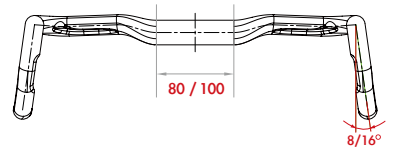
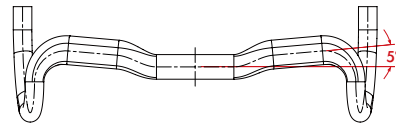
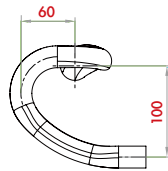

SPECIAL ERGONOMIC CUT OUT

HAWK



MATERIAL	AL6066
BAR BORE	Ø31.8 mm
WIDTH	380 / 400 / 420 / 440 / 460 mm
RISE	0 mm
Drop	100 mm
REACH	60 mm
FLARE	8 / 16 degree

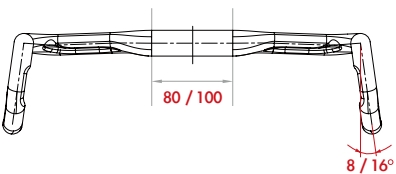
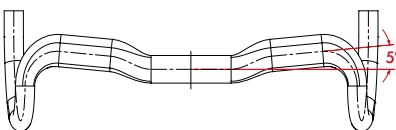
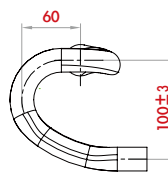

SWIFT

MATERIAL	AL6066
CENTER DIA	Ø31.8 mm
WIDTH	380 / 400 / 420 / 440 / 460 mm
DROP (D)	120 mm
REACH (R)	65 mm
FLARE	8° / 16°
WEIGHT	364 g (W:440)

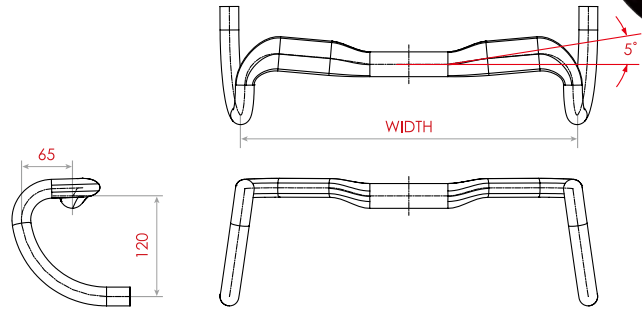
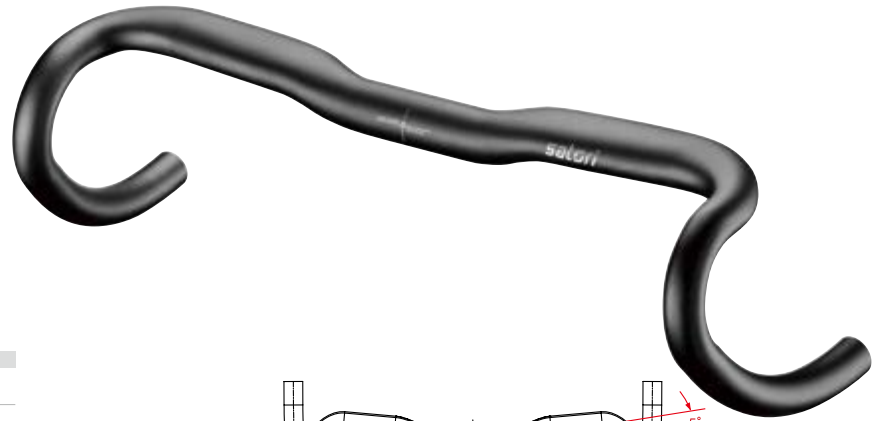

RAPTOR

MATERIAL	AL6066
CENTER DIA	Ø31.8 mm
WIDTH	380 / 400 / 420 / 440 / 460 mm
DROP (D)	113 mm
REACH (R)	97 mm
FLARE	8° / 16°
WEIGHT	358.5 g (W:400)

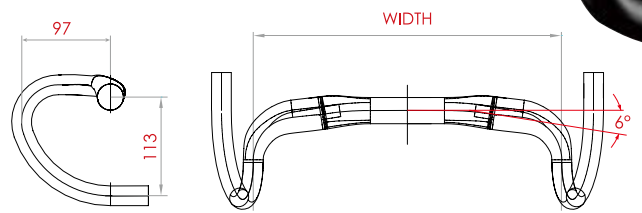

S'AVANTE

MATERIAL	AL6066
CENTER DIA	Ø31.8 mm
WIDTH	400 / 420 / 440 / 460 mm
DROP (D)	136 mm
REACH (R)	70 mm
FLARE	8° / 16°
WEIGHT	345 g (W:440)

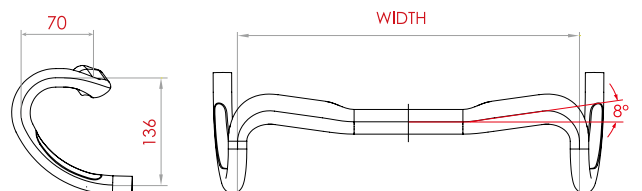

X-RACE AERO

MATERIAL	AL6066
CENTER DIA	Ø31.8 mm
WIDTH	380 / 400 / 420 / 440 / 460 mm
DROP (D)	122 mm
REACH (R)	70 mm
FLARE	8° / 16°
WEIGHT	326.5 g (W:420, 8°)



X-RACE PRO

MATERIAL	AL6061
CENTER DIA	Ø31.8 mm
WIDTH	380 / 400 / 420 / 440 / 460 mm
DROP (D)	120 mm
REACH (R)	70 mm
FLARE	8° / 16°
WEIGHT	335 g (W:420, 8°)



FURIO PRO



MATERIAL	AL6061
CENTER DIA	Ø31.8 mm
WIDTH	380 / 400 / 420 / 440 mm
DROP (D)	118 mm
REACH (R)	70 mm
FLARE	0° / 8°
WEIGHT	298.5 g (W:420)



STEMS

HANDLEBARS

SEATPOSTS

CARBON SERIES

ACCESSORIES



FIREBIRD

MATERIAL	AL6066
WIDTH	440 / 460 / 480 mm
BAR BORE	Ø31.8 mm
DROP	110 mm
REACH	76 mm
WELDING PART REACH	133 mm
FLARE	30°
WEIGHT	535 g (W:480)

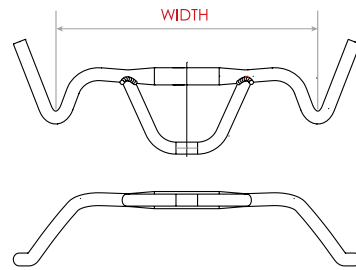

B-Tech

FLARED
DROP

FALCON AERO

MATERIAL	AL6061
CENTER DIA	Ø31.8 mm
WIDTH	700 / 720 / 740 / 760 mm
RISE	0 mm
BACK SWEEP	15°
REACH	120 mm
WEIGHT	351 g (W:760)

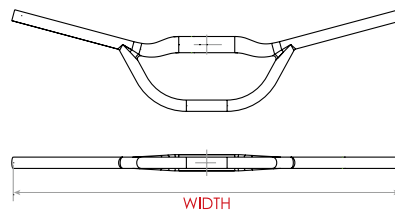

B-Tech



DELTA CITY

MATERIAL	AL6061
EXTENSION	80 / 90 / 100 mm
WIDTH	600 / 630 mm
RISE	17 mm
BACK SWEEP	15 / 35°
WEIGHT	502 g (W:620 / E:80)



DELTA URBAN

MATERIAL	AL6061
EXTENSION	80 / 90 / 100 mm
WIDTH	580 / 600 / 620 mm
RISE	5 mm
BACK SWEEP	9°
WEIGHT	448 g (W:600 / E:70)



STEMS

HANDLEBARS

SEATPOSTS

CARBON SERIES

ACCESSORIES

OPTIONAL



SPR-010



EL-010



EL-019
Transition spacer for use
with ACROS AZX-581



JUNIOR



MAT BK

MATERIAL	AL6061
CENTER DIA	Ø25.4 mm
WIDTH	420 / 440 / 460 / 480 / 500 / 620 / 680 mm
RISE	25 mm
BACK SWEEP	7°
WEIGHT	209 g (W:420)



B-Tech

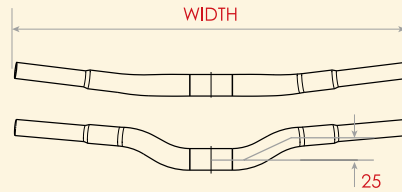

STEMS



PRODIGY



MAT BK

MATERIAL	AL6061
CENTER DIA	Ø25.4 mm
WIDTH	500 / 540 / 600 mm
RISE	15 mm
BACK SWEEP	9°
WEIGHT	234 g (W:600)



B-Tech

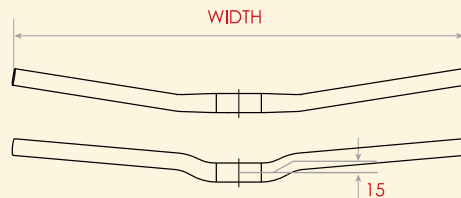

HANDLEBARS

SEATPOSTS

CARBON SERIES

ACCESSORIES

JOEY



MAT BK

Simple. Safe. Smart.

JOEY is a cleanly designed stem for kids' bikes, featuring front-facing bolts to reduce injury risk during impact. A thoughtful solution that puts young rider safety first.

MATERIAL	FORGED AL
EXTENSION	40 / 60 mm
BAR BORE	Ø25.4 mm
STEERER	Ø28.6 mm
ANGLE	15°
STEERER DEPTH	40 mm
WEIGHT	154 g

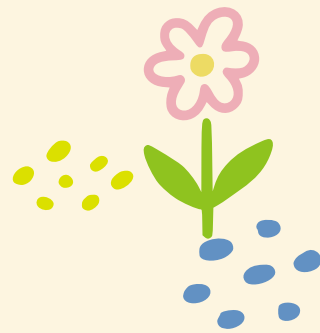



New clamp system, easy open and close

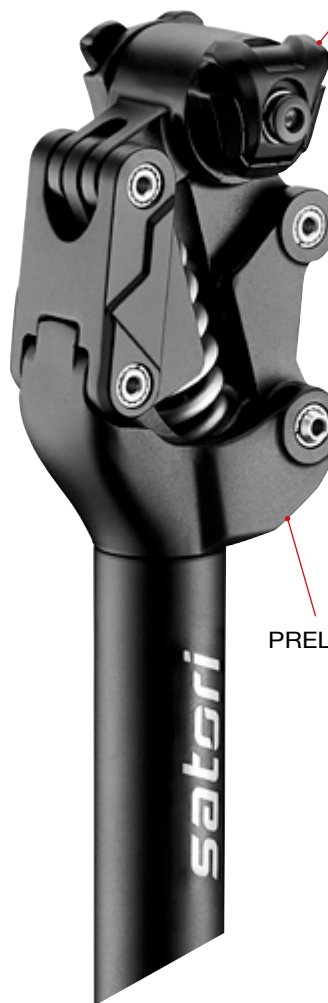

PRELOAD ADJUST

STEMS

HANDLEBARS

SEATPOSTS

CARBON SERIES

ACCESSORIES

SPRING BOX



Approved for Cat. 2 ETK 180Kg

MATERIAL	FORGED
OFF SET	24 mm
ANGLE	-5° ~ +18°
DIAMETER	Ø27.2 / Ø30.9 / Ø31.6 / Ø34.9 mm
LENGTH	350 / 400 / 450 mm
WEIGHT	753.5 g (Ø34.9)



OPTIONAL

SPRING DIAMETER WITH DIFFERENT HARDNESS AVAILABLE AS OPTION

Standard : 60-80KG

Firm : 80-110Kg

GLIDERBOX



Approved for Cat. 2 ETK 180Kg

MATERIAL	FORGED
OFF SET	13 mm
ANGLE	-5° ~ +18°
DIAMETER	Ø30.9 / Ø31.6 mm
LENGTH	350 / 400 / 450 mm
WEIGHT	718 g (Ø31.6 x 350)





PATENTED ANTI SIDEPLAY SYSTEM



Based on the patented quadrilateral and one piece forged stanchion, SATORI suspension seatpost is utterly immune to sideplay. The coil spring provides just the right amount of compression and rebound damping, also the pre-load can be easily adjusted to rider's weight. By adding SATORI suspension seatpost you'll ride faster, longer and less fatigue, all in the sense of great comfort.



HARMONY SA

MATERIAL	FORGED / AL6061
OFF SET	3 mm
ANGLE	-5° ~ +18°
DIAMETER	Ø27.2 / Ø30.9 / Ø31.6 mm
LENGTH	300 / 350 mm
TRAVEL	40 mm
WEIGHT	634 g (Ø31.6 x 350)



ELEGANCE-LT

MATERIAL	FORGED / AL6061
OFF SET	18 mm
ANGLE	-5° ~ +18°
DIAMETER	Ø27.2 / Ø30.9 / Ø31.6 / Ø34.9 mm
LENGTH	300 / 350 mm
TRAVEL	40 mm
WEIGHT	688.5 g (Ø34.9 x 400)





HARMONY-LT2

MATERIAL	FORGED / AL6061
OFF SET	10 mm
ANGLE	-5° ~ +18°
DIAMETER	Ø27.2 / Ø30.9 / Ø31.6 / Ø34.9 mm
LENGTH	300 / 350 mm
TRAVEL	40 mm
WEIGHT	492.5 g (Ø27.2 x 350)



XOPIC2

MATERIAL	FORGED / AL6061
OFF SET	0 mm
ANGLE	-5° ~ +18°
DIAMETER	Ø27.2 / Ø30.9 / Ø31.6 / Ø34.9 mm
LENGTH	300 / 350 / 400 / 450 mm
TRAVEL	40 mm
WEIGHT	497.5 g (Ø30.9 x 350)



IMPEND-LF

MATERIAL	FORGED / AL6061
OFF SET	17 mm
ANGLE	-5° ~ +18°
DIAMETER	Ø27.2 mm
LENGTH	300 / 350 mm
TRAVEL	40 mm
WEIGHT	526 g (Ø27.2 x 350)



STEMS

HANDLEBARS

SEATPOSTS

CARBON SERIES

ACCESSORIES

SPTM
CONNECT

compatible for SP Connect E- Cap system



New clamp system, easy open and close

STEMS

HANDLEBARS

SEATPOSTS

CARBON SERIES

ACCESSORIES

ORION



MATERIAL	AL6066
OFF SET	0 mm
ANGLE	- 5° ~ +18°
DIAMETER	Ø27.2 / Ø30.9 / Ø31.6 / Ø34.9 mm
WEIGHT	302 g (Ø31.6 x 350)



OPTIONAL



S³ ADAPTOR

ARTEMIS



MATERIAL	AL6066
OFF SET	15 mm
ANGLE	- 5° ~ +18°
DIAMETER	Ø27.2 / Ø30.9 / Ø31.6 / Ø34.9 mm
WEIGHT	322 g (Ø31.6 x 350)

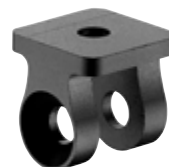

S³ LIGHT MOUNT



STEMS

HANDLEBARS

SEATPOSTS

CARBON SERIES

ACCESSORIES

SORATA LT

MATERIAL	AL6066
OFF SET	10 mm
ANGLE	-5° ~ +18°
DIAMETER	Ø31.6 / Ø34.9 mm
LENGTH	334 ~ 475 mm
WEIGHT	660 g

SORATA

MATERIAL	AL6066
OFF SET	20 mm
ANGLE	-5° ~ +18°
DIAMETER	Ø31.6 / Ø34.9 mm
LENGTH	280 ~ 440 mm
WEIGHT	567 g (34.9)

SORATA 0

MATERIAL	AL6066
OFF SET	0 mm
ANGLE	-5° ~ +18°
DIAMETER	Ø31.6 / Ø34.9 mm
LENGTH	280 ~ 440 mm
WEIGHT	567 g (34.9)



STEMS

HANDLEBARS

SEATPOSTS

CARBON SERIES

ACCESSORIES



Unleash the Ride: Meet the All-New ATLAS MECCANO Electronic Dropper Post

Elevate your mountain biking and e-bike experience with the ATLAS MECCANO, a revolutionary electronically driven dropper post engineered for ultimate trail performance.



WIRELESS REMOTE

ATLAS MECCANO



DIAMETER	30.9 / 31.6 mm
TRAVEL	100 / 125 / 150 / 175 mm
DRIVE MODULE	Under-mounted drive module specifically for dropper posts
POWER SUPPLY	12V 1A vehicle power supply
RELAY WIRING	2 wires (PWR, GND), Compatible with various brands of power cable terminal
WIRELESS CONTROL	2.4GHz RF signal control
WATERPROOF RATING	IP66
COMPATIBLE SYSTEM	BOSCH®, SHIMANO®, etc.



ATLAS LITE

MATERIAL	3D FORGED / AL7050
OFF SET	0 mm
ANGLE	-5° ~ +18°
DIAMETER	Ø27.2 mm
LENGTH	390 mm / Travel 80 mm 390 mm / Travel 100 mm
WEIGHT	599.5 g (Ø27.2, T:100)

ATLAS PRO

MATERIAL	AL7050
OFF SET	0 mm
ANGLE	- 5° ~ +18°
DIAMETER	Ø30.9 / Ø31.6 mm
LENGTH	307 mm / T:80 mm 350 mm / T:100 mm 403 mm / T:125 mm 455 mm / T:150 mm 505 mm / T:175 mm 560 mm / T:200 mm
WEIGHT	462 g (T:80 mm) 489.4 g (T:100 mm) 520.3 g (T:125 mm) 550.7 g (T:150 mm) 573.2 g (T:175 mm) 607.9 g (T:200 mm)

ATLAS LIFT



MATERIAL	AL6066
OFF SET	0 mm
ANGLE	- 5° ~ +18°
DIAMETER	Ø30.9 / Ø31.6 mm
LENGTH	413 mm / T:80 mm 456 mm / T:100 mm
WEIGHT	572 g (T:80 mm) 605 g (T:100 mm)

STEMS

HANDLEBARS

SEATPOSTS

CARBON SERIES

ACCESSORIES



TRIDENT OF

MATERIAL	TUBE AL6066 or CARBON
OFF SET	18 mm
ANGLE	-5° ~ +18°
DIAMETER	Ø27.2 / Ø30.9 / Ø31.6 / Ø34.9 mm
LENGTH	305 / 355 / 405 mm
WEIGHT	288 g (Ø27.2 x 355, AL6066)

TRIDENT

MATERIAL	TUBE AL6066 or CARBON
OFF SET	0 mm
ANGLE	-5° ~ +18°
DIAMETER	Ø27.2 / Ø30.9 / Ø31.6 / Ø34.9 mm
LENGTH	300 / 350 / 400 mm
WEIGHT	307 g (Ø27.2 x 350, AL6066)



CAMBER

MATERIAL	TUBE AL6066 or CARBON
OFF SET	24 mm
CRADLE	43 x 38
ANGLE	-5° ~ +18°
DIAMETER	Ø27.2 / Ø30.9 / Ø31.6 / Ø34.9 mm
LENGTH	315 / 365 / 415 mm
WEIGHT	311.5 g (Ø31.6 x 365, AL6066)

COMET

MATERIAL	TUBE AL6066 or CARBON
OFF SET	0 mm
CRADLE	43 x 35
ANGLE	-5° ~ +18°
DIAMETER	Ø27.2 / Ø30.9 / Ø31.6 / Ø34.9 mm
LENGTH	300 / 350 / 400 mm
WEIGHT	370.5 g (Ø34.9 x 350, AL6066)

ASTRO

MATERIAL	TUBE AL6066 or CARBON
OFF SET	20 mm
CRADLE	43 x 35
ANGLE	-5° ~ +18°
DIAMETER	Ø27.2 / Ø30.9 / Ø31.6 / Ø34.9 mm
LENGTH	300 / 350 / 400 mm
WEIGHT	342 g (Ø31.6 x 350, AL6066)

S' PRESSO-B Remote Lever

For those who run 1X, we present you a new dropper post remote lever.

- Positioned under handlebar for easier thumb access and clean look
- Adjustable lever position



S' PRESSO-A Remote Lever



HORIZON BOW CARBON



DEVIANT BOW CARBON

HORIZON BOW CARBON



ACF

Approved for Cat.4 EMTB 150Kg

MATERIAL	Full CARBON
CENTER DIA	Ø31.8 mm
WIDTH	720 / 740 / 760 / 780 mm
RISE	7 mm
BACK SWEEP	9°
WEIGHT	213 g (W:740)

DEVIANT BOW CARBON



ACF

Approved for Cat.4 EMTB 150Kg

MATERIAL	Full CARBON
CENTER DIA	Ø31.8 mm
WIDTH	720 / 740 / 760 / 780 mm
RISE	12 mm
BACK SWEEP	9°
WEIGHT	237 g (W:780)



EVO 35 CARBON XL



EVO 35 CARBON XS

EVO 35 CARBON XL



ACF

Approved for Cat.4 EMTB 150Kg

MATERIAL	Full CARBON
CENTER DIA	Ø35 mm
WIDTH	720 / 740 / 780 / 800 mm
RISE	40 mm
BACK SWEEP	7°
WEIGHT	234.5 g (W:800)

EVO 35 CARBON XS



ACF

Approved for Cat.4 EMTB 150Kg

MATERIAL	Full CARBON
CENTER DIA	Ø35 mm
WIDTH	720 / 740 / 780 / 800 mm
RISE	20 mm
BACK SWEEP	7°
WEIGHT	231 g (W:800)



Ø35



Ø35

ACCESSORIES



GoPro MOUNT



STARSTREAM MINI faceplate



688B CAP



S³ LIGHT MOUNT

MATERIAL	Engineering Plastic	Alloy	Alloy	Alloy
PRODUCT COMPATIBILITY	VIPER 0 / NEW VIPER / RANA / MONDERATOR	VIPER 0 / NEW VIPER / RANA / MONDERATOR	SHORTY ICR 35mm	S³ Interface



S³ ADAPTOR



MAT BK



Faceplate adaptor for INTUVIA 100



MAT BK



Faceplate adaptor for KIOX 300



MAT BK

MATERIAL	Engineering Plastic	Engineering Plastic	Engineering Plastic
PRODUCT COMPATIBILITY	S³ Interface	671B / 380F / 379 / EL-012	671B / 380F / 379 / EL-012



S³ CAP



671B CAP



380F CAP



379 CAP

MODEL	Faceplate	Light mount Faceplate	Light mount Faceplate	Light mount Faceplate
MATERIAL	Alloy	Alloy	Alloy	Alloy
PRODUCT COMPATIBILITY	VIPER 0, NEW VIPER / RANA, MODERATOR	PYTHON / FASTBACK 20 / 35 / HATCHBACK, SIDEWINDER / SHORTY ICR (31.8 mm), ET5	UP3	UP3
REMARK		Pitch:10.3 / 11.5 mm	Pitch:10.3 / 11.5 mm	Pitch:10.3 mm

STEMS

HANDLEBARS

SEATPOSTS

CARBON SERIES

ACCESSORIES

**EL-045**

MODEL	Light mount for SLINGSHOT
MATERIAL	Engineering Plastic
PRODUCT	SLINGSHOT
REMARK	Pitch:10.3 mm

**EL-012**

MODEL	Light mount adaptor
MATERIAL	Alloy
PRODUCT	RANA, URSA VIPER 0 NEW VIPER, MODERATOR
REMARK	Pitch:10.3 / 11.5 mm

**EL-017**

MODEL	Light mount adjustable adaptor
MATERIAL	Engineering Plastic
PRODUCT	380F CAP 379 CAP EL-012, EL-045 671B CAP
REMARK	S3 light mount

**EL-023**

MODEL	Countersunk Lock screw
MATERIAL	Stainless steel
PRODUCT	For all light mount and EL-017

**EL-019**

MODEL	Transit spacer for ACROS
MATERIAL	Engineering Plastic
PRODUCT COMPATIBILITY	FASTBACK 20 / 35 DELTA series SIDEWINDER
REMARK	Specialized for the stem to compatible for the normal stem to match with ACROS AICR plastic parts

**SPR-010**

MODEL	SPACER
MATERIAL	Engineering Plastic
PRODUCT COMPATIBILITY	FASTBACK 20 / 35 DELTA series HATCHBACK, SIDEWINDER EZ-X
REMARK	Options:5 mm / 10 mm

**EL-010**

MODEL	DUST CAP
MATERIAL	Alloy
PRODUCT COMPATIBILITY	FASTBACK 20 / 35 DELTA series HATCHBACK, SIDEWINDER EZ-X

**EL-018**

MODEL	Light mount for CATAMARAN
MATERIAL	Engineering Plastic
PRODUCT COMPATIBILITY	CATAMARAN
REMARK	35 mm Bar bore, Pitch:10 / 20 mm

**EL-025**

MODEL	S ³ plug for UP3
MATERIAL	Engineering Plastic
PRODUCT COMPATIBILITY	UP3

**EL-007**

MODEL	Di2 battery adapter
MATERIAL	Engineering Plastic
REMARK	27.2 mm seat post

STEMS

HANDLEBARS

SEATPOSTS

CARBON SERIES

ACCESSORIES

		Light mount	Light mount adaptor	Countersunk Lock screw	Phone mount	ACROS ICR
	BELUGA	S ³ Light mount	EL-017	EL-023	N/A	AZX-585
	BOXTER	S ³ Light mount	EL-017	EL-023	N/A	AZX-585
	MOBY DEE	S3 Light mount	EL-017	EL-023	On Top	AZX-585
	SLINGSHOT	EL-045	EL-017	EL-023	On Top	AZX-585
	PYTHON	671B CAP	EL-017	EL-023	On Top	AZX-585
	CATAMARAN	EL-018	EL-017	EL-023	N/A	AZX-585
	SHORTY ICR (Ø31.8/35mm)	671B CAP (31.8mm only)	EL-017 (31.8mm only)	EL-023 (31.8mm only)	On Top	AZX-585
	HATCHBACK ICR	671B CAP	EL-017	EL-023	On Top	AZX-585
	RANA	EL-012	EL-017	EL-023	S ³ CAP	AZX-727
	NEW VIPER	EL-012	EL-017	EL-023	S ³ CAP	AIX-526
	VIPER 0	EL-012	EL-017	EL-023	S ³ CAP	AZX-581
	URSA	EL-012	EL-017	EL-023	N/A	AZX-581 / AIX-288

FSA ICR	TOKEN ICR	Transit spacer for ACROS	DUST CAP	SPACER	Display holder
HS-CRP-A01	TK3266-SC2	N/A	N/A	N/A	N/A
HS-CRP-A01	TK3266-SC2	N/A	N/A	N/A	N/A
HS-CRP-A01	TK3266-SC2	N/A	N/A	N/A	EL-038 / EL-034
HS-CRP-A01	TK3266-SC2	N/A	N/A	N/A	EL-038 / EL-034
HS-CRP-A01	TK3266-SC2	N/A	N/A	N/A	EL-038 / EL-034
HS-CRP-A01	TK3266	N/A	N/A	N/A	EL-038 / EL-034
HS-CRP-A01	TK3266-SC2	N/A	N/A	N/A	EL-038 / EL-034
HS-CRP-A01	TK3266-SC2	N/A	N/A	N/A	EL-038 / EL-034
HS-CRP-A03	TK3266-SC1	N/A	N/A	N/A	EL-038 / EL-034
HS-CRP-A04	TK2156 TK2166	N/A	N/A	N/A	EL-038 / EL-034
No.80 / 62 / CRII	TK2156 TK2166	N/A	N/A	N/A	EL-038 / EL-034
No.80 / 62 / CRII	TK2156 TK2166	N/A	N/A	N/A	EL-038 / EL-034

STEMS

HANDLEBARS

SEATPOSTS

CARBON SERIES

ACCESSORIES

STEMS

HANDLEBARS

SEATPOSTS

CARBON SERIES

ACCESSORIES

		Light mount	Light mount adaptor	Countersunk Lock screw	Phone mount	ACROS ICR
	SIDEWINDER	671B CAP	EL-017	EL-023	On Top	AZX-581 / AZF-656
	FASTBACK 20	671B CAP	EL-017	EL-023	On Top	AZX-581 / AZF-656
	FASTBACK 35	671B CAP	EL-017	EL-023	On Top	AZX-581 / AZF-656
	HATCHBACK	671B CAP	EL-017	EL-023	On Top	N/A
	UP3	380F / 379 CAP	EL-017	EL-023	EL-025	N/A
	ET-5	671B CAP	EL-017	EL-023	On Top	N/A
	EZ-X ICR	N/A	N/A	N/A	On Top	AZX-585
	EZ-X	N/A	N/A	N/A	On Top	N/A
	MODERATOR	EL-012	EL-017	EL-023	On Top	N/A
	COBRA (only for Ø31.8mm)	380F / 379 CAP	EL-017	EL-023	N/A	N/A
	TURN UP (only for Ø31.8mm)	380F / 379 CAP	EL-017	EL-023	N/A	N/A

FSA ICR	TOKEN ICR	Transit spacer for ACROS	DUST CAP	SPACER	Display holder
NO.69 / 56 / SRS / Middle / HL-Delta	TK2156 TK2166	EL-019	EL-010	SPR-010	EL-038 / EL-034
NO.69 / 56 / SRS / Middle / HL-Delta	TK2156 TK2166	EL-019	EL-010	SPR-010	EL-038 / EL-034
NO.69 / 56 / SRS / Middle / HL-Delta	TK2156 TK2166	EL-019	EL-010	SPR-010	EL-038 / EL-034
N/A	N/A	N/A	EL-010	SPR-010	EL-038 / EL-034
N/A	N/A	N/A	N/A	N/A	EL-038 / EL-034
N/A	N/A	N/A	N/A	N/A	EL-038 / EL-034
HS-CEP-AO1	TK3266-SC2	N/A	N/A	N/A	N/A
N/A	N/A	N/A	EL-010	SPR-010	N/A
N/A	N/A	N/A	N/A	N/A	EL-038 / EL-034
N/A	N/A	N/A	N/A	N/A	EL-038 / EL-034
N/A	N/A	N/A	N/A	N/A	EL-038 / EL-034

STEMS

HANDLEBARS

SEATPOSTS

CARBON SERIES

ACCESSORIES

satori

18 Kuang Fu North Road Hsinchu Industrial Park
Hu Ko Hsinchu Hsien, Taiwan.
TEL: 886-3-5983721 FAX: 886-3-5981861

 www.facebook.com/satoribike



satoribike.com

